



The Peak Candlepower Myth –

Beam Uniformity versus Peak Candlepower





The Myth of Peak Candlepower – The Trakkabeam[®] Advantage

The most important aspect of searchlight technology is the ability to put effective light on the target to achieve maximum visibility. For the last thirty-five years, searchlight manufacturers have offered virtually no change in how the light beam is projected onto the target plane. They use only a single optical component - the reflector - for projection of the beam.

The problem with the inefficient, single-element, reflector design of searchlights such as those currently used in many airborne applications, is that the light beam is not uniform. When the beam is widened to cover a large target area, a black hole develops in the center of the beam. As the beam is narrowed in focus, the dark hole in the center disappears as the light energy is pushed to the beam center, leaving the outside edges virtually unusable. The hot spot at beam center is where the peak candlepower rating is derived.

As you will see in the charts that follow, peak candlepower has little to do with overall searchlight performance. In Figure 1 below, notice that the typical 1600 watt searchlight's beam profile has a sharp peak at the center. This peak beam rating of 30 million candlepower is taken when the beam is at its most narrow angle – four degrees. It is clear from the chart that at a four degree focus (+2° and -2°), the beam spread/pattern has little energy outside a small area in the beam center.

Competitor's 1600 Watt Searchlight Beam

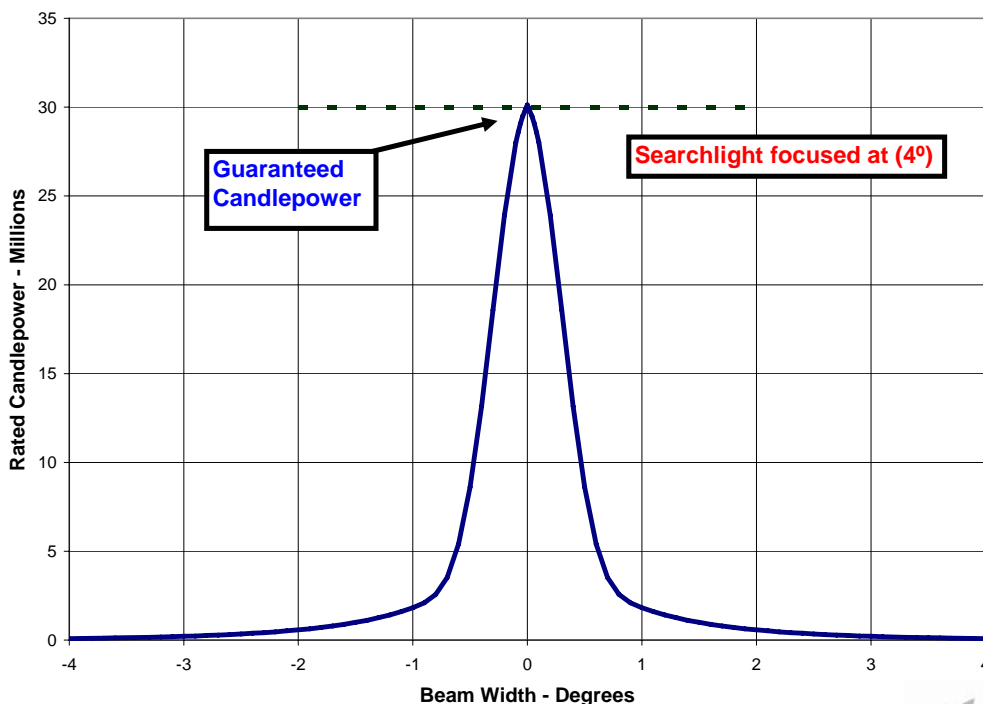

Figure 1 – Typical Searchlight Beam

Copyright 2007 Trakka Corp Pty Ltd. All rights reserved

Figure 2 offers another view of the peak candlepower myth. It depicts the beam energy in a three dimensional form. The peak candlepower number makes good advertising promotion, but falls short of producing an impressive beam. The negative consequence of achieving the peak candlepower “hot spot” is the fact that the human eye responds to the peak hot spot by dilating the pupil to the point that the beam edges appear almost dark, which reduces the effective illumination of the beam. This is why **beam uniformity** plays such a large role in tactical operations – not **peak candlepower**.

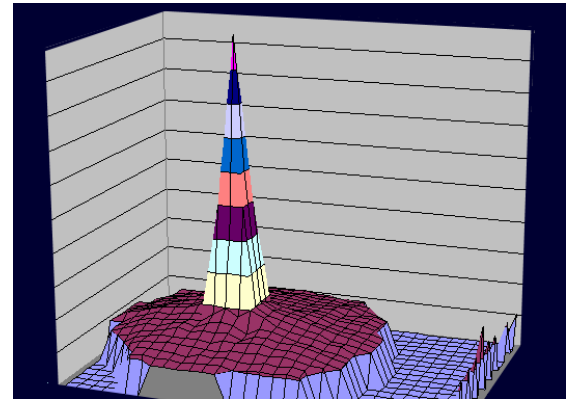

Figure 2 – Typical Beam at Narrow Focus

Trakkabeam® searchlights eliminate the problems of older technology searchlight systems with an entirely new concept in searchlight performance. At the heart of the system is a patent-pending optical design far superior to antiquated designs of the past. The multi-element optics of the Trakkabeam®

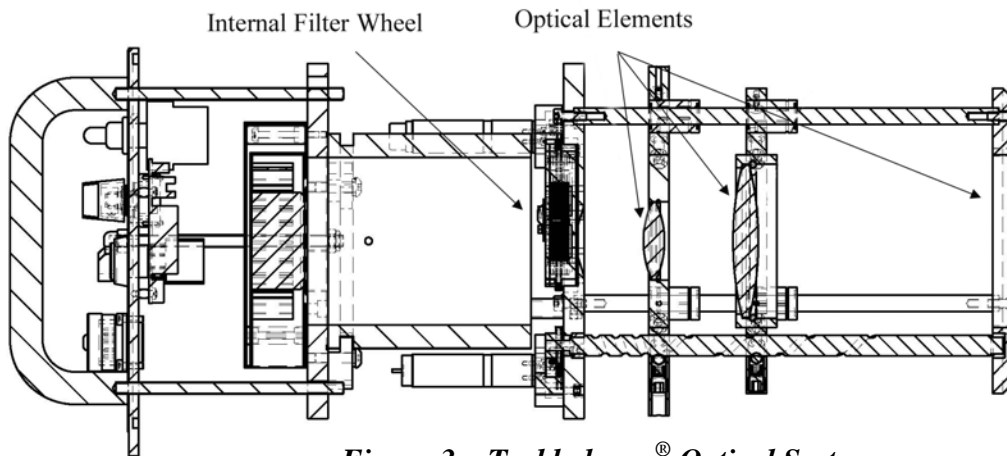

Figure 3 – Trakkabeam® Optical System

searchlights are so efficient at collecting light energy that they utilize a xenon lamp which requires about half the input energy (800 watts) to produce a superior beam with uniform edges. Figure 4 shows the beam energy of the Trakkabeam®. Notice how the energy fills the outer edges when compared to other searchlights, and the absence of a candlepower “peak.” This is why Trakkabeam® searchlights are not advertised with peak candlepower comparisons – we only advertise the usable energy on target. **Real data, real world performance.**

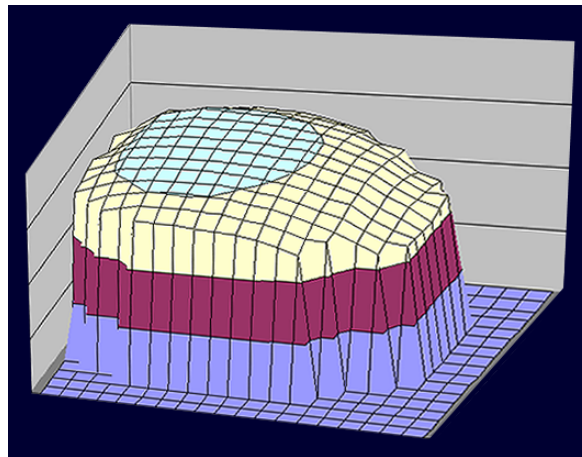

Figure 4 – Trakkabeam® Uniformity



What does all of this talk about peak candlepower mean in terms of performance? The photos below tell the entire story.



Competitors 1600 Watt Beam -Left Trakkabeam's 800 Watt Beam

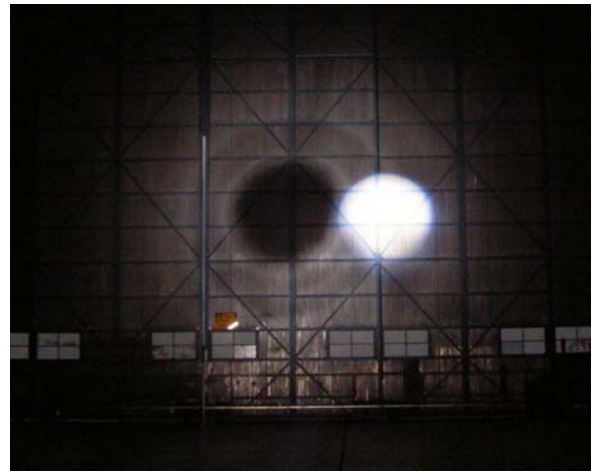

Competitors 1600 Watt Beam -Left Trakkabeam's 800 Watt Beam

These photos were taken recently at a police airwing facility. They are actual, un-retouched photos showing the Trakkabeam[®] searchlight beam compared side-by-side with a widely used 1600 watt searchlight. Both photos were taken in the hangar with both projecting from a distance of approximately 31 meters (102 feet). Both photos show the Trakkabeam[®] on right, the 1600 watt beam on the left. In photo 1, the typical beam was optimized for the best beam performance – about a six degree beam spread. Even at this optimum setting, it is apparent how uneven the beam is. The outer edges of the beam have little energy, while the center has an overwhelming hot spot. Note how clean and even the beam of the Trakkabeam[®] appears – with half the input energy required for the 1600 watt version. Photo 2 shows the almost unusable beam of the 1600 watt light at wide focus. The signature dark hole in the beam center is characteristic of this older design. Trakkabeam[®] outshines and outperforms.

This is what we call the “Trakkabeam[®] Advantage”:

- Fully DO-160E tested and rated
- Weighs less
- Less input energy required
- Aerodynamic profile
- Uniform beam profile
- Dual control functionality available
- Slave capability for imaging systems, moving maps, available
- Internal spectral filters with no external moving parts or bulk – from extremely covert IR to UV
- Light beam doesn't shake or vibrate in flight

For more information, visit www.trakkacorp.com, or contact us for your nearest Trakkabeam[®] dealer.